

Code No: 155AX

JAWAHARLAL NEHRU TECHNOLOGICAL UNIVERSITY HYDERABAD

B. Tech III Year I Semester Examinations, February - 2022

DESIGN OF MACHINE MEMBERS - I

(Mechanical Engineering)

Time: 3 hours

Max. Marks: 75

Answer any five questions  
All questions carry equal marks

- - -

- 1.a) Explain the design considerations in machine design and explain the design process.  
b) A 25 mm diameter shaft is made of forged steel 30C8 ( $S_{ut} = 600 \text{ N/mm}^2$ ). There is a step in the shaft and the theoretical stress concentration factor at the step is 2.1. The notch sensitivity factor is 0.84. Determine the endurance limit of the shaft if it is subjected to a reversed bending moment. [5+10]
- 2.a) How can the strength of low carbon steel can be increased?  
b) The force acting on a bolt consists of two components—an axial pull of 12 kN and a transverse shear force of 6 kN. The bolt is made of steel FeE 310 ( $S_{yt} = 310 \text{ N/mm}^2$ ) and the factor of safety is 2.5. Determine the diameter of the bolt using the maximum shear stress theory of failure. [5+10]
- 3.a) Explain the difference between endurance limit and fatigue strength of a material.  
b) Determine the thickness of a 120 mm wide uniform plate for safe continuous operation if the plate is to be subjected to a tensile load that has a maximum value of 250 kN and a minimum value of 100 kN. The endurance limit stress is 225 MPa, yield point stress is 300 MPa and factor of safety is 1.5. [5+10]
- 4.a) How will you reduce stress concentration in threaded parts?  
b) A machine component is subjected to fluctuating stress that varies from 40 to 100  $\text{N/mm}^2$ . The corrected endurance limit stress for the machine component is 270  $\text{N/mm}^2$ . The ultimate tensile strength and yield strength of the material are 600 and 450  $\text{N/mm}^2$  respectively. Find the factor of safety using (i) Gerber theory and (ii) Soderberg line. [5+10]
- 5.a) Describe about the welding inspection. What are the methods of welding inspection?  
b) How much length of a 10 mm fillet weld is required to weld the long side of an ISA angle  $150 \times 75 \times 10$  to a steel plate with side welds only? A static load of 125 kN acts through the centre of gravity of the angle section which is 53.2 mm from the short side. The allowable load per mm of the weld length is 665 N. [5+10]

- 6.a) Explain the methods of increasing the shock absorbing capacity of the bolt.
- b) An eccentrically loaded bracket is welded to the support as shown in figure. The permissible shear stress for the weld material is  $55 \text{ N/mm}^2$  and the load is static. Determine the throat and leg dimensions for the welds. [5+10]

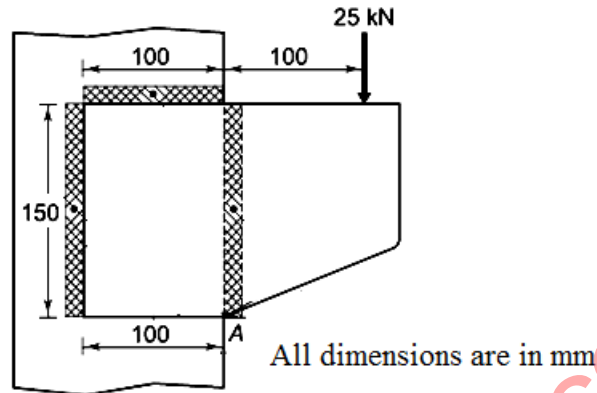

- 7.a) Explain the construction of Knuckle joint with the help of neat sketch.
- b) Why is cotter provided with a taper? Why is a taper provided only on one side? [7+8]
- 8.a) Explain why hollow shaft has greater strength and stiffness than solid shaft of equal weight?
- b) How will you design shaft on the basis of torsional rigidity? [8+7]

---ooOoo---